

Yealink MP50 User Guide V1.0

Contents

About This Guide.....	4
How to Connect.....	4
Connect to PC via USB Cable.....	4
Connect to PC/Smartphone/Bluetooth Headset via Bluetooth.....	5
BT50 LED Indicator.....	5
Single Bluetooth Connection.....	5
Two Bluetooth Connections.....	6
Disconnect and Remove Your Bluetooth Device.....	7
Edit Your Bluetooth Information.....	7
Turn off Bluetooth.....	7
How to Use.....	7
Hardware Overview.....	8
Icons and Status Indicators.....	9
Adjust the Playback Volume.....	9
Reset Configuration.....	9
How to Manage Calls.....	10
Basic Call Usage.....	10
Merge Two Calls.....	11
Multiple Calls Handling.....	11
Yealink USB Connect.....	11
Manually Pair the Phone with BT50.....	12
Download and Install.....	13
Update Firmware.....	14
How to Change Settings.....	15
Change the Default Outgoing Dialer Device.....	15
Change the Default Media Playback Device.....	15
Basic Settings.....	16
Advanced Settings.....	17
Optional Accessories.....	17
Busylight BLT60.....	17
Bluetooth Dongle BT50.....	18
FAQ.....	18
How to set up my device to work with Microsoft Teams?.....	18
How to set up my device to work with Microsoft Skype for Business?.....	19
Why can't I hear the other party's voice?.....	19

Why is the time on my device not synchronized with the PC?.....	20
Why does the phone display “PC Device” or “PC softphone” instead of the name and number of the other party for a Skype for Business incoming call?.....	20
Is my PC compatible?.....	21
Is my smartphone compatible?.....	22
Is my Bluetooth headset compatible?.....	23

About This Guide

This guide contains instructions for connecting and using your MP50 USB phone.

How to Connect

- [Connect to PC via USB Cable](#)
- [Connect to PC/Smartphone/Bluetooth Headset via Bluetooth](#)

Connect to PC via USB Cable

Procedure

Connect the phone to PC using the attached USB cable.

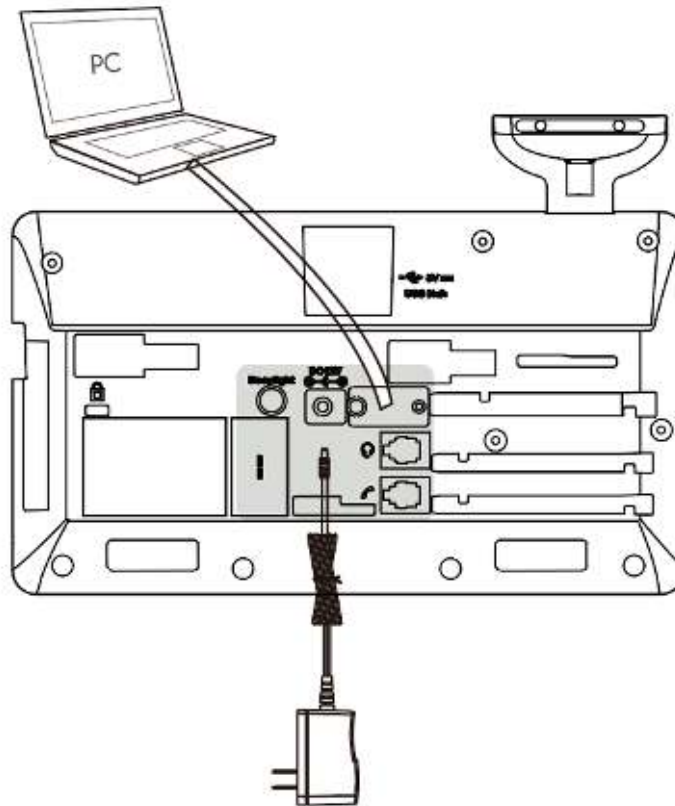

Note: For more information on compatible PC, refer to the specific FAQ.

Related information

[Is my PC compatible?](#)

Connect to PC/Smartphone/Bluetooth Headset via Bluetooth

You can connect your phone to PC, smartphone, or Bluetooth Headset via Bluetooth. And then you can use your phone to perform call controls for the softphone/smartphone.

The phone can save the pairing information of 8 Bluetooth devices connected recently.

- [BT50 LED Indicator](#)
- [Single Bluetooth Connection](#)
- [Two Bluetooth Connections](#)
- [Disconnect and Remove Your Bluetooth Device](#)
- [Edit Your Bluetooth Information](#)
- [Turn off Bluetooth](#)

BT50 LED Indicator

BT50 LED Indicator

LED Indicator	Description
Flashing blue	Bluetooth connecting
Solid blue	Bluetooth connected
Off	Bluetooth disconnected

Single Bluetooth Connection

You can connect to PC or smartphone via Bluetooth.

- [Connecting to PC](#)
- [Connecting to Smartphone](#)
- [Connecting to Bluetooth Headset](#)

Connecting to PC

You can connect the phone to PC via Bluetooth dongle BT50. The phone and the BT50 are pre-paired and ready to use out of the box. The Bluetooth range is 30m/100ft.

About this task

 **Note:** If you connect the phone to PC via built-in Bluetooth, the phone can only support voice pickup and audio playback.

Procedure

Connect the BT50 into a USB port on your PC.



After successful connection, the BT50 LED indicator glows blue.

 **Note:** To manually pair the phone with the BT50, please use Yealink USB connect. For more information on the compatible PC, refer to the specific FAQ.

Related tasks

[Manually Pair the Phone with BT50](#)

Related information

[Is my PC compatible?](#)

Connecting to Smartphone

You can connect the phone to smartphone via built-in Bluetooth.



Procedure

1. Tap  or the user account avatar, and tap **Bluetooth**.
The phone automatically enters the pairing mode.
2. On your smartphone, turn on Bluetooth and select **Yealink MP50**.
3. Select **Pair** on both the phone and your smartphone.

 **Note:** The Yealink MP50 is the default device name. You can edit the phone's Bluetooth device name. For more information on the compatible smartphone, refer to the specific FAQ.

Related tasks

[Edit Your Bluetooth Information](#)

Related information

[Is my smartphone compatible?](#)

Connecting to Bluetooth Headset

You can connect the phone to Bluetooth headset via built-in Bluetooth.

Procedure

1. Tap  or the user account avatar, and tap **Bluetooth**.
The phone automatically enters the pairing mode.
2. Turn on Bluetooth on your Bluetooth headset.
3. Select the desired Bluetooth headset to pair.
4. Press the MUTE key on the phone.

 **Note:** For more information on the compatible Bluetooth headset, refer to the specific FAQ.

Related tasks

[Edit Your Bluetooth Information](#)

[Connecting to Bluetooth Headset](#)



Two Bluetooth Connections

You can connect up to two Bluetooth devices at the same time.

Disconnect and Remove Your Bluetooth Device

You can disconnect your Bluetooth device from your phone and still keep it paired. When you disconnect a Bluetooth device, it remains paired so that you can reconnect it to your phone. You can also remove your Bluetooth device so that it is no longer paired or connected to the phone.



Procedure

1. Tap  or the user account avatar, and tap **Bluetooth**.
2. Tap the connected Bluetooth device, and select **Disconnect**.
3. Tap , and select **Unpair**.
The screen prompts you whether to end the pair with the device.
4. Confirm the action.

Edit Your Bluetooth Information

You can change the phone's Bluetooth device name to identify your phone to other devices.

Procedure

1. Tap  or the user account avatar, and tap **Bluetooth**.
2. Tap **My Bluetooth Information**.
3. Select  to edit the device name.

Turn off Bluetooth

Procedure

1. Tap  or the user account avatar, and tap **Bluetooth**.
2. Turn off **Bluetooth**.

How to Use

- [Hardware Overview](#)
- [Icons and Status Indicators](#)
- [Adjust the Playback Volume](#)
- [Reset Configuration](#)



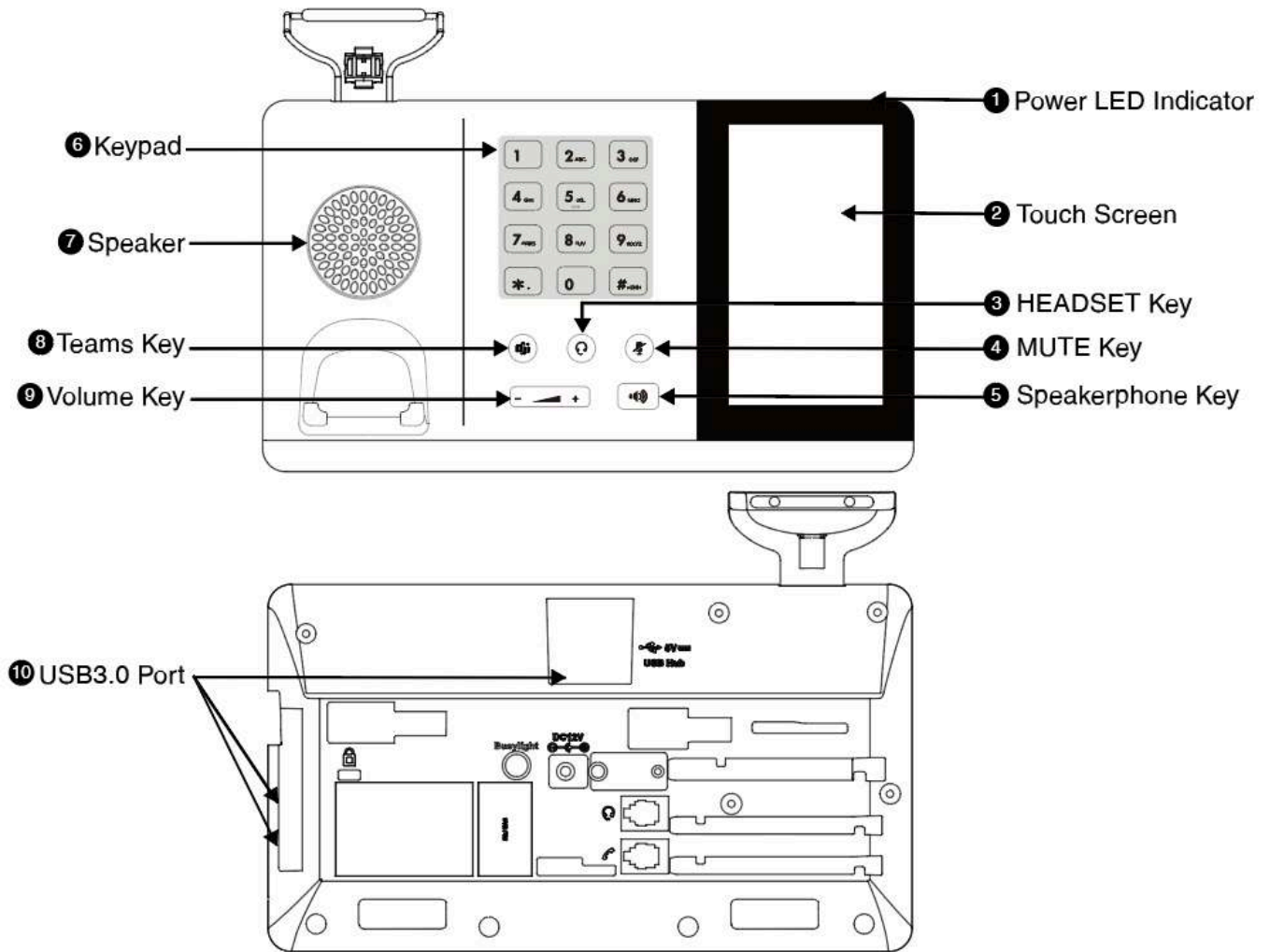

Hardware Overview



Name		Description
1	Power LED Indicator	Indicates the phone status.
2	Touch Screen	Allows you to select items and navigate menus on the touch-sensitive screen.
3	HEADSET Key	Toggles and indicates the headset mode. The key LED glows green when headset mode is activated.
4	MUTE Key	Toggles and indicates mute feature. The key LED glows red when the call is muted.
5	Speakerphone Key	Toggles and indicates the hands-free (speakerphone) mode. The key LED glows green when the hands-free (speakerphone) mode is activated.

Name		Description
6	Keypad	Provides the digits and special characters in context-sensitive applications.
7	Speaker	Provides hands-free (speakerphone) audio output.
8	Teams Key	<ul style="list-style-type: none"> • Hold for 2 seconds to activate Cortana integrated in Teams (this requires Microsoft's support). • Press once to invoke the Teams client in the idle state.
9	Volume Key	Adjusts the volume of the handset, headset, and speaker.
10	USB3.0 Port	Allows you to connect a USB headset/USB flash drive/Bluetooth dongle BT50 and so on.

Icons and Status Indicators

Icon	Description
	Smartphone
	PC
	Bluetooth mode is on, but no mobile device is connected
	Bluetooth mode is on, and a mobile device is connected

Adjust the Playback Volume

Procedure

Do one of the following:

- Press the Volume key.
- Tap  or the user account avatar.

Go to **Settings > Basic Settings > Speaker Volume**.

Tap the desired value.

Reset Configuration

Procedure

1. Do one of the following:

- Tap  or the user account avatar.
Go to **Settings > Advanced Settings > Reset Configuration**.
- Long press the pound key (#) and the star key (*) for about 6 seconds when the phone is idle.

The screen prompts you whether to reset configuration or not.

2. Confirm the action.









Results

The phone will reboot and all settings will return to their default values.

How to Manage Calls

- [Basic Call Usage](#)
- [Merge Two Calls](#)
- [Multiple Calls Handling](#)

Basic Call Usage

Function	Action
Place a new call	<ol style="list-style-type: none"> 1. Tap the connected device CARD or . 2. Enter the desired number. 3. Select the desired outgoing dialing device. 4. Tap Call.
Answer call	Tap  .
End call	Tap  .
Reject call	Tap  .
Hold call	Tap  .
Resume call	Tap Resume .
Mute/un-mute microphone	Tap  /  on the screen or press the MUTE key.
Place a new call during a call	Tap  .

Related information

[Hardware Overview](#)



Merge Two Calls

You can merge two calls into one conference call.

Before you begin





There are two calls on the phone, and one of them is on the connected USB device.

Procedure

1. Tap  > **Merge Calls**.
2. To split the conference, tap  > **Split Conf**.

Multiple Calls Handling

The phone can accept and handle multiple calls at the same time.

Multiple Call Handling	Action
End the current call and answer the incoming call	Tap  and then tap  .
Put current call on hold and answer the incoming call	Tap  on the phone.
Switch between held call and active call	Tap  on the phone.
Reject incoming call, while on a current call	Tap  on the phone.

Yealink USB Connect

Yealink USB Connect is a computer software designed to manage Yealink USB devices.

With Yealink USB Connect you can:

- Get an overview of connected Yealink USB devices
- Manage your Yealink USB devices (for example, change basic/advanced settings, BT50 pair management)
- Update your Yealink USB device to enhance its performance and features
- Give feedback on your Yealink USB device

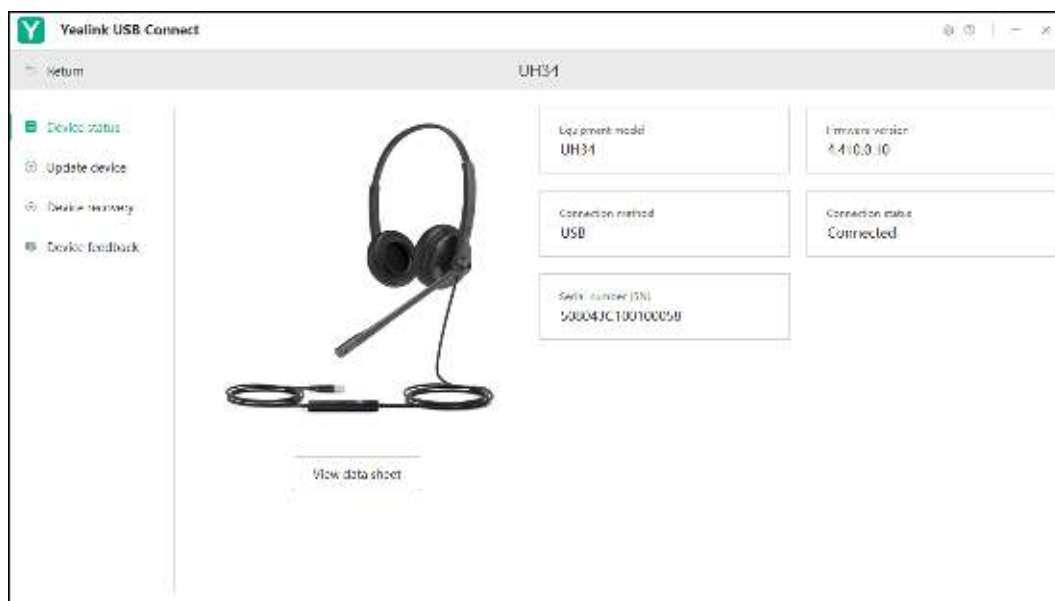
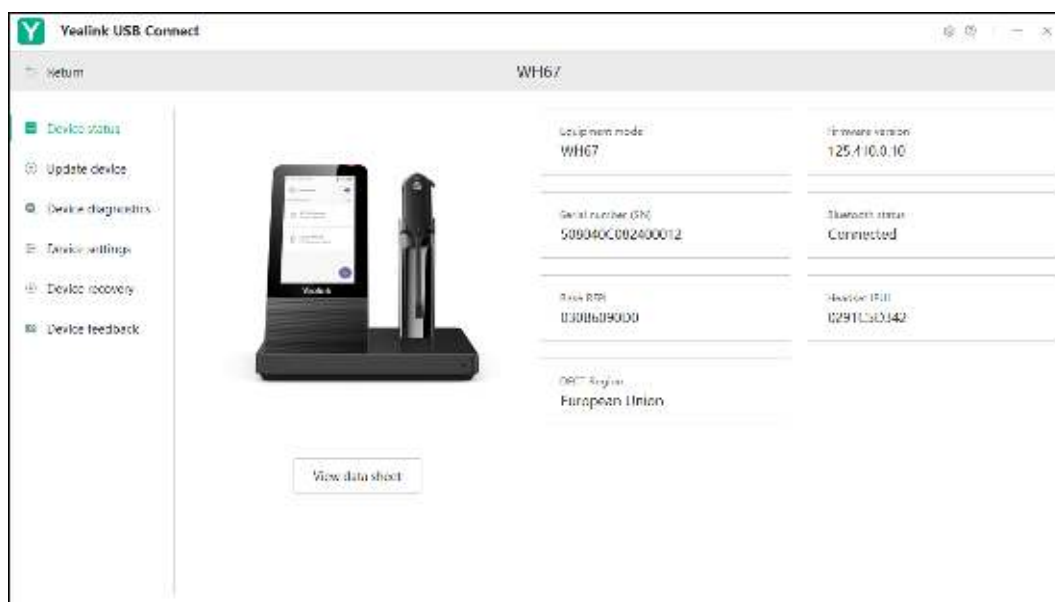

 **Note:** Download via support.yealink.com.

- [Manually Pair the Phone with BT50](#)
- [Download and Install](#)
- [Update Firmware](#)

Manually Pair the Phone with BT50

Before you begin

Make sure that the MP50 is in the Bluetooth pairing mode or is connected to the same PC with BT50.

Procedure

1. Click **Pair Management**.
2. Optional: In the **Pairable devices List** field, click  to search the pairable device.

3. Find the desired device and click **Start pairing**.

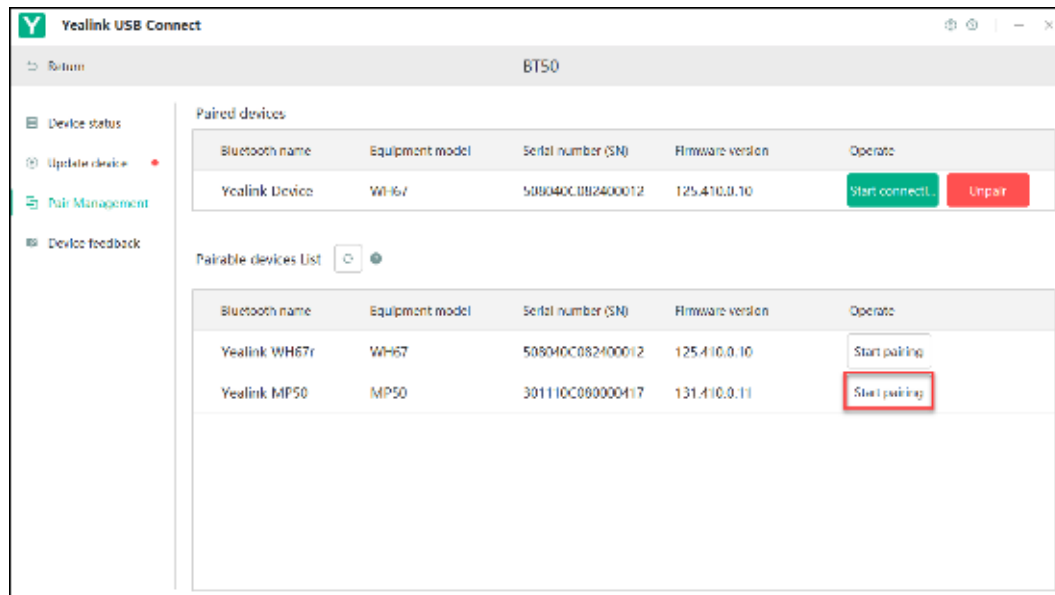

For more information on Yealink USB Connect, refer to [Yealink USB Device Manager Client User Guide](#).

Download and Install

Before you begin

Connect the phone to your PC.

Procedure

1. If it is the first time to connect the phone to your PC, the PC prompts you as shown below:

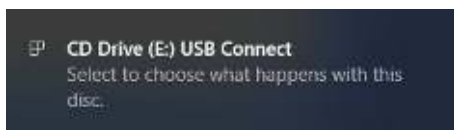

- Click the prompt box and run the program.

CD Drive (E:) USB Connect

Choose what to do with this disc.

Install or run program from your media

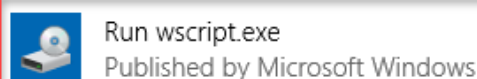

Other choices

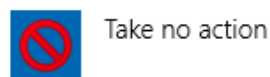
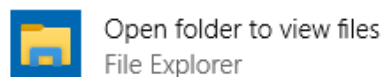

- Download the Yealink USB Connect on the web page.

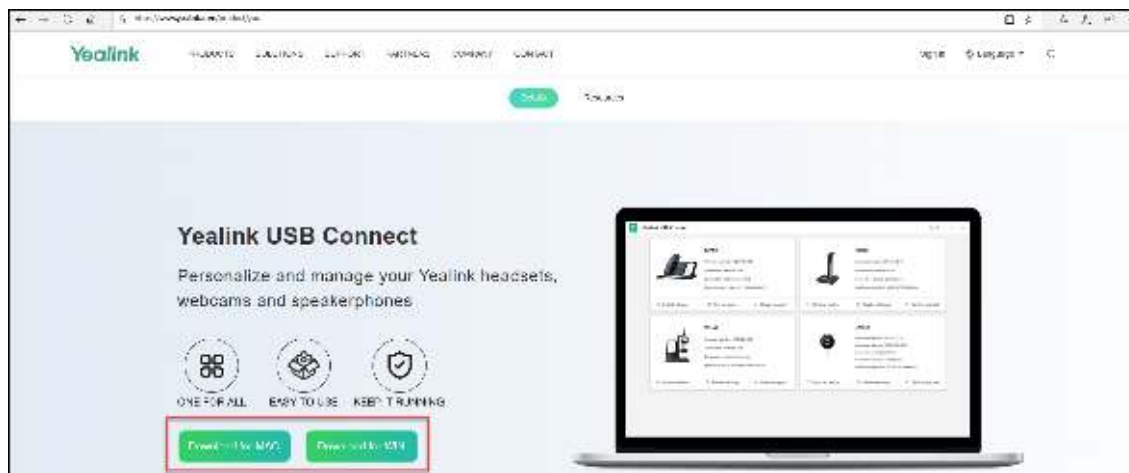

If the prompt box disappears, you can double-click the **CD drive: USB Connect** in the devices and drives list.

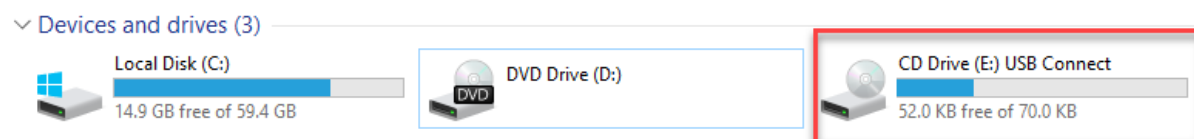

Download the Yealink USB Connect on the web page.

- Note:** If it detects that Yealink USB Connect has been installed after connecting, Yealink USB Connect will automatically run.

Update Firmware

Procedure

1. Connect the phone to the USB port of PC.
2. Update the phone firmware via Yealink USB Connect.
 - Check for updates
 - Update manually



For more information on Yealink USB Connect, refer to [Yealink USB Device Manager Client User Guide](#).

How to Change Settings

Phone and general settings can be changed on the phone screen.

- [Change the Default Outgoing Dialer Device](#)
- [Change the Default Media Playback Device](#)
- [Basic Settings](#)
- [Advanced Settings](#)

Change the Default Outgoing Dialer Device

Procedure

1. Tap ******* on the idle screen.
2. Tap the desired connected device.

Change the Default Media Playback Device



You can change the default music playback device.

Procedure

1. Tap  on the idle screen.
2. Tap the desired connected device.

Basic Settings

Tap  or the user account avatar, and go to **Settings > Basic Settings** to access the basic settings menu.

General Settings	
Language	Select the screen text language from a list of 15 languages.
Bluetooth	Enable/disable the Bluetooth.
Time&Date	Set the time and date manually.
Busylight	<p>Set the busylight status or turn off the busylight.</p> <ul style="list-style-type: none"> • Sync (the status depends on the Presence status for Skype for Business) • Available (LED glows green when the device is not in a call or not ringing) • DND (LED glows red when the device is not in a call or not ringing) • Off (LED is off) <p>Note: It appears only when you connect the Busylight BLT60 to the phone.</p>
Display Settings	
Backlight	Set the backlight active level and backlight time.
Screensaver	Change the waiting time for screen saver.
Teams User Name	<p>Configure whether the Teams user name displays on the home screen when the device disconnects with PC.</p> <ul style="list-style-type: none"> • Personal Mode (default): Display the Teams user name when the device disconnects with PC. • Hot Desking Mode: Do not display the Teams user name when the device disconnects with PC. <p> Note: It is only available for Teams version.</p>
Dark Theme	<p>Turn on/off dark theme.</p> <p>The dark theme changes the default bright background color to a darker color, which is easier on the eyes in low-light environments or if you prefer less bright screens.</p> <p> Note: It is only available for Teams version.</p>
Sound Settings	
Ring Tones	Enable/disable the phone to play a built-in tone while receiving an incoming call.

Dial Tone	Enable/disable the paired headset to play a dial tone when entering the dialing screen.
Keypad Tone	Enable/disable the paired headset to produce a sound when pressing the keypad keys.
Speaker Volume	Adjust the playback volume.

Related tasks

[Busylight BLT60](#)

Advanced Settings

Tap  or the user account avatar, and go to **Settings > Advanced Settings** to access the advanced settings menu.

Calling Settings	
Auto Dial	Enable/disable the phone to automatically dial the entered number within 5 seconds.
Call Priority	Select which call takes priority when a second call is accepted. <ul style="list-style-type: none"> • New call: The first call is placed on hold and the new call is active. • Current call: The first call is active and the new call is placed on hold.

Optional Accessories

The phone can use optional accessories when you need to extend your phone's capabilities.

The following optional accessories need to be purchased separately if required for your phone:

1. Busylight BLT60
2. BT50
 - [Busylight BLT60](#)
 - [Bluetooth Dongle BT50](#)

Related information

[Connect to PC/Smartphone/Bluetooth Headset via Bluetooth](#)

Busylight BLT60

When the phone is connected to PC, busylight can alert you to the status of the Microsoft Teams/Skype for Business client.

About this task

LED States	Description
Presence Status (sync status requires softphone support)	
LED glows green	Available

LED States	Description
LED glows orange	Away
LED glows red	DND/Busy
Talking Status	
LED fast flashes red	Ringling
LED glows red	In a call
LED slowly flashes green	Missed call/voice message notification (this requires softphone support)
LED off	Microsoft Teams/Skype for Business client is not running, turn off the busylight

Related information[Basic Settings](#)

Bluetooth Dongle BT50

You can connect the MP50 to PC via Bluetooth dongle BT50.

Procedure

Connect the BT50 into a USB port on your PC.

The MP50 and the BT50 are pre-paired and ready to use out of the box. You can also pair the phone and the BT50 via Yealink USB connect.

Related tasks[Manually Pair the Phone with BT50](#)

FAQ

- [How to set up my device to work with Microsoft Teams?](#)
- [How to set up my device to work with Microsoft Skype for Business?](#)
- [Why can't I hear the other party's voice?](#)
- [Why is the time on my device not synchronized with the PC?](#)
- [Why does the phone display "PC Device" or "PC softphone" instead of the name and number of the other party for a Skype for Business incoming call?](#)
- [Is my PC compatible?](#)
- [Is my smartphone compatible?](#)
- [Is my Bluetooth headset compatible?](#)

How to set up my device to work with Microsoft Teams?

Procedure

1. Click on your profile picture at the top of the Teams window.

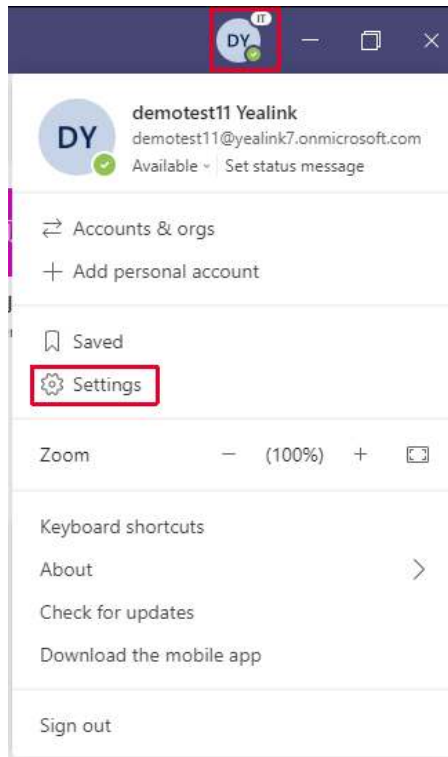

2. Click **Settings > Devices**.
3. Select your Yealink MP50 device under **Audio devices** field.

How to set up my device to work with Microsoft Skype for Business?

Procedure

1. Click the **Settings** icon in the top-right corner of the **Skype for Business** window.
2. In the left side options, click **Audio Device**.
3. In **Audio Device**, select your MP50 device.

Why can't I hear the other party's voice?

The device is not set as the default audio device for PC. Use the audio settings in the sound control panel / preferences to select the headset as the default audio device.

For WIN 8/ WIN 8.1/ WIN 10 OS:

1. Go to **Control Panel > Hardware and Sound > Sound**.
2. In the **Playback** tab, highlight the desired headset and select **Set Default**.
3. Confirm the action.

For MAC OS:

1. Go to your **System Preferences > Sound**.
2. In the **Output** tab, select the MP50 as your **Playback Device**.

For more information, refer to the web resources.

Why is the time on my device not synchronized with the PC?

Check if the Yealink USB Connect/Microsoft Teams/Skype for Business is running on the PC, the device time will automatically synchronize with the PC time when you connected MP50 to the PC. Otherwise, you need to set the time manually at the **Basic Settings** menu on the phone.

Related information

[Basic Settings](#)

Why does the phone display "PC Device" or "PC softphone" instead of the name and number of the other party for a Skype for Business incoming call?

The MP50 driver for Windows may be abnormal. You need to reinstall the driver in the Windows Device Manager, and then disconnect and reconnect the MP50 to PC.

Procedure

1. Open **Device Manage**.
2. Delect the USB input devices with the hardware ID "6993".

3. You can right-click the **USB Input Device** and check the hardware ID in **Details** tab.

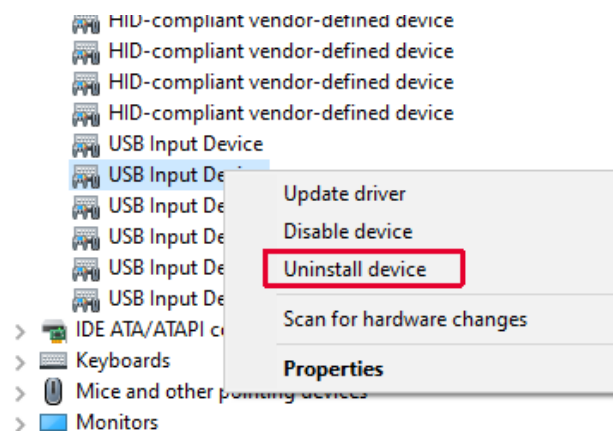
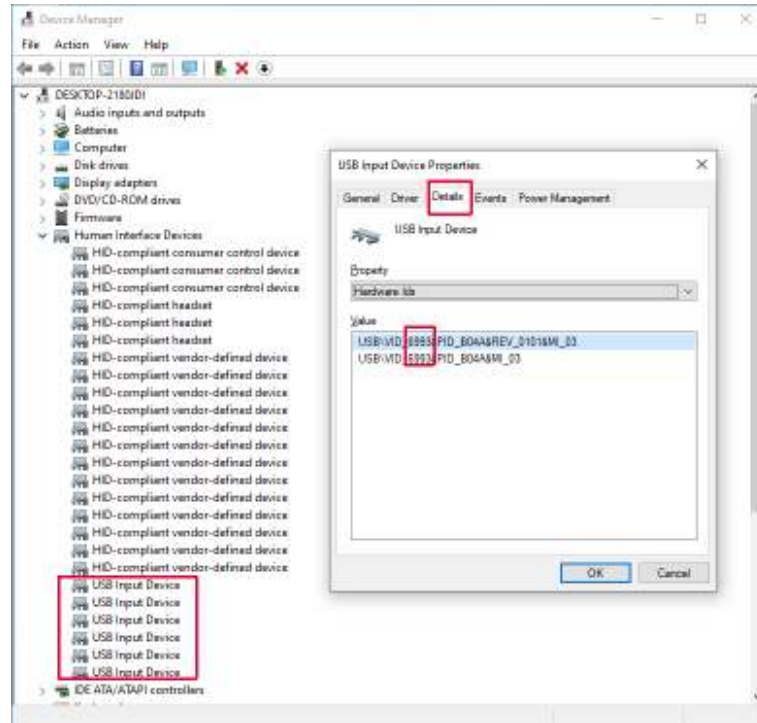

4. Uninstall the MP50 device in the **Sound, video and game controllers** module.

5. Disconnect and reconnect MP50 to your PC.

Is my PC compatible?

The tested PC list compatible with Yealink MP50:

PC Model	OS	Connectivity	Softphone
HP ELITEBOOK 840G5	win10 1903	USB Cable	Microsoft Teams
			Skype for Business
Surface Book	win10 1903		Microsoft Teams
			Skype for Business
ASPIRE 4750G	win10 1903		Microsoft Teams

PC Model	OS	Connectivity	Softphone
			Skype for Business
			Microsoft Teams
MAC Book Pro	10.15.2		Skype for Business
			Microsoft Teams
Mac Book Air	10.15.5		Skype for Business
			Microsoft Teams
Thinkpad X270	win10 1903		Skype for Business
			Microsoft Teams
Thinkpad X220i	win8 9200		Skype for Business
			Microsoft Teams
DELL	win10 1903	Skype for Business	
		Microsoft Teams	
HP ELITEBOOK 840G5	win10 1903	BT50	Skype for Business
			Microsoft Teams
ASPIRE 4750G	win10 1903		Skype for Business
			Microsoft Teams
MAC Book Pro	10.15.2		Skype for Business
			Microsoft Teams
Mac Book Air	10.14.6		Skype for Business
			Microsoft Teams
Thinkpad X270	win10 1903		Skype for Business
			Microsoft Teams
Thinkpad X220i	win8 9200		Skype for Business
			Microsoft Teams
DELL	win10 1903		Skype for Business
			Microsoft Teams

Is my smartphone compatible?

The tested smartphone list compatible with Yealink MP50:

Mobile Phone Model	System
iPhone 11	iOS 13.3.1
Huawei Mate30	Android 10
Huawei P30 Pro	Android 10
Samsung Galaxy S10	Android 10

Mobile Phone Model	System
Samsung GALAXY Note 10	Android 10
Xiaomi CC9 pro	Android 10
Xiaomi Mi Mix 2	Android 10
vivo X27	Android 9.0
Google Pixel	Android 10
Google Nexus6	Android 6.0.1
Samsung Galaxy S7	Android 8.0
Sony Xperia	Android 8.0

Is my Bluetooth headset compatible?

The tested Bluetooth headset list compatible with Yealink MP50:

Manufacturer	Model
Jabra	Evolve 75
	pro9470
	MOTION UC(3)
	Jabra speaker 810
	STEALTH
	Style
	Talk 2
Sennheiser	PRESENCE UC
	MB Pro 2
	MB660 UC
Plantronics	VOYAGER 5200 UC
	ML20
	Edge
	B825(Focus)
Iphone	Apple AirPods
YAMAHA	YVC-1000